

Application : Drill & Screwdriver 、 Robot Vacuum

用途：電動工具、智能吸塵機器人

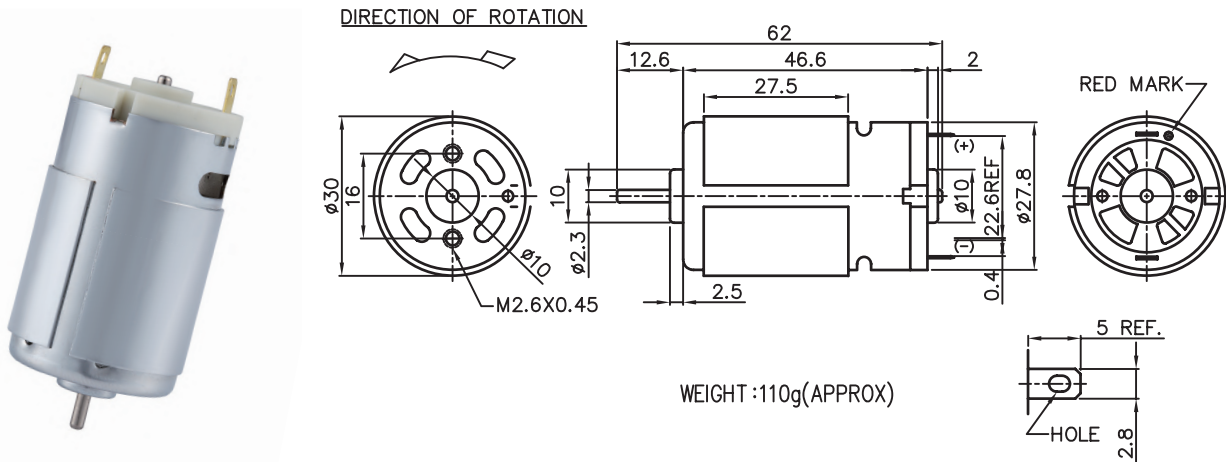

MODEL	VOLTAGE		NO LOAD		AT MAXIMUM EFFICIENCY					STALL			
	OPERATING RANGE	NOMNAL	SPEED rpm	CURRENT A	SPEED rpm	CURRENT A	TORQUE g-cm	OUTPUT mN-m	EFF W	%	CURRENT A	TORQUE g-cm	mN-m
JD3-4532-R	4.8 - 9.6	9.6V CONSTANT	20000	0.80	16800	5.60	223	23.86	38.73	72	36.39	1662	162.94
JD3-5520-R	3.6 - 7.2	7.2V CONSTANT	23500	1.50	19500	8.17	191	18.73	38.35	66	42.45	1214	119.02
JD3-14260-R	6.0 - 24.0	12.0V CONSTANT	3000	0.06	2300	0.22	64	6.27	1.54	60	0.91	334	32.75
JD3-3066-R	6.0 - 18.0	12.0V CONSTANT	12500	0.35	10661	1.96	160	15.69	17.50	77	13.28	1240	121.57

馬達的出軸長度及性能參數，EMC 對策可依客人要求做調整，詳情可詢問相關業務人員。
Please inquire your sales representative for output, performance and EMC solution.

