

Application : Drill & Screwdriver 、 Pump

用途：電動工具、泵浦

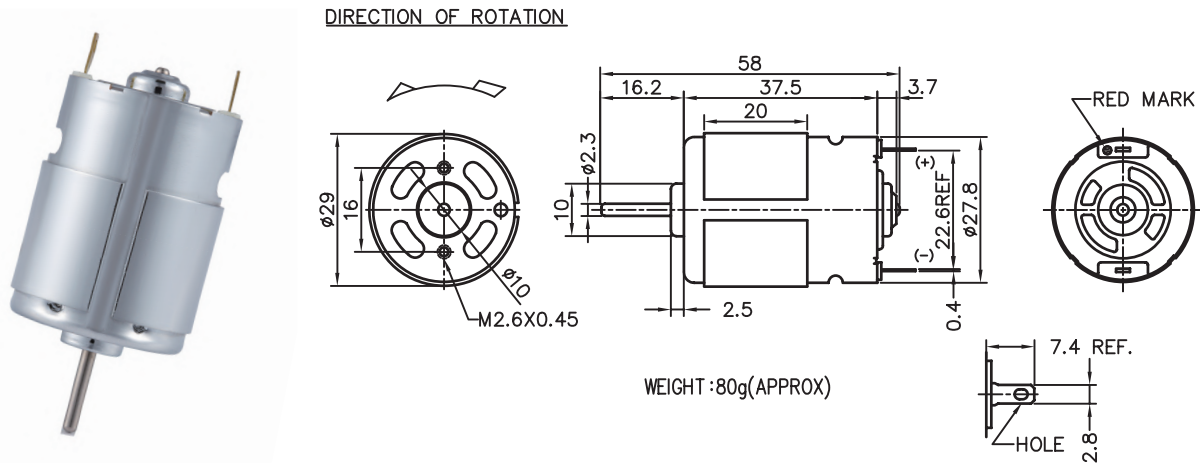

MODEL	VOLTAGE		NO LOAD		AT MAXIMUM EFFICIENCY						STALL		
	OPERATING RANGE	NOMNAL	SPEED rpm	CURRENT A	SPEED rpm	CURRENT A	TORQUE g-cm	OUTPUT mN-m	EFF W	%	CURRENT A	TORQUE g-cm	mN-m
LS3FN-12300-R	6.0-24.0	9.6V CONSTANT	3100	0.06	2300	0.17	31	3.04	0.74	49	0.54	136	13.33
LS3FN-14280-R	6.0-24.0	12.0V CONSTANT	4300	0.07	3400	0.23	42	4.12	1.49	57	0.98	243	23.82
LD3FN-5015-R	2.4- 4.8	4.0V CONSTANT	25000	2.10	19900	10.77	135	13.24	27.69	65	41.90	627	61.47
LD3FN-26110-R	6.0-18.0	18.0V CONSTANT	15000	0.22	12800	1.60	149	14.61	19.61	69	9.85	1050	102.94

馬達的出軸長度及性能參數，EMC 對策可依客人要求做調整，詳情可詢問相關業務人員。
Please inquire your sales representative for output, performance and EMC solution.

